

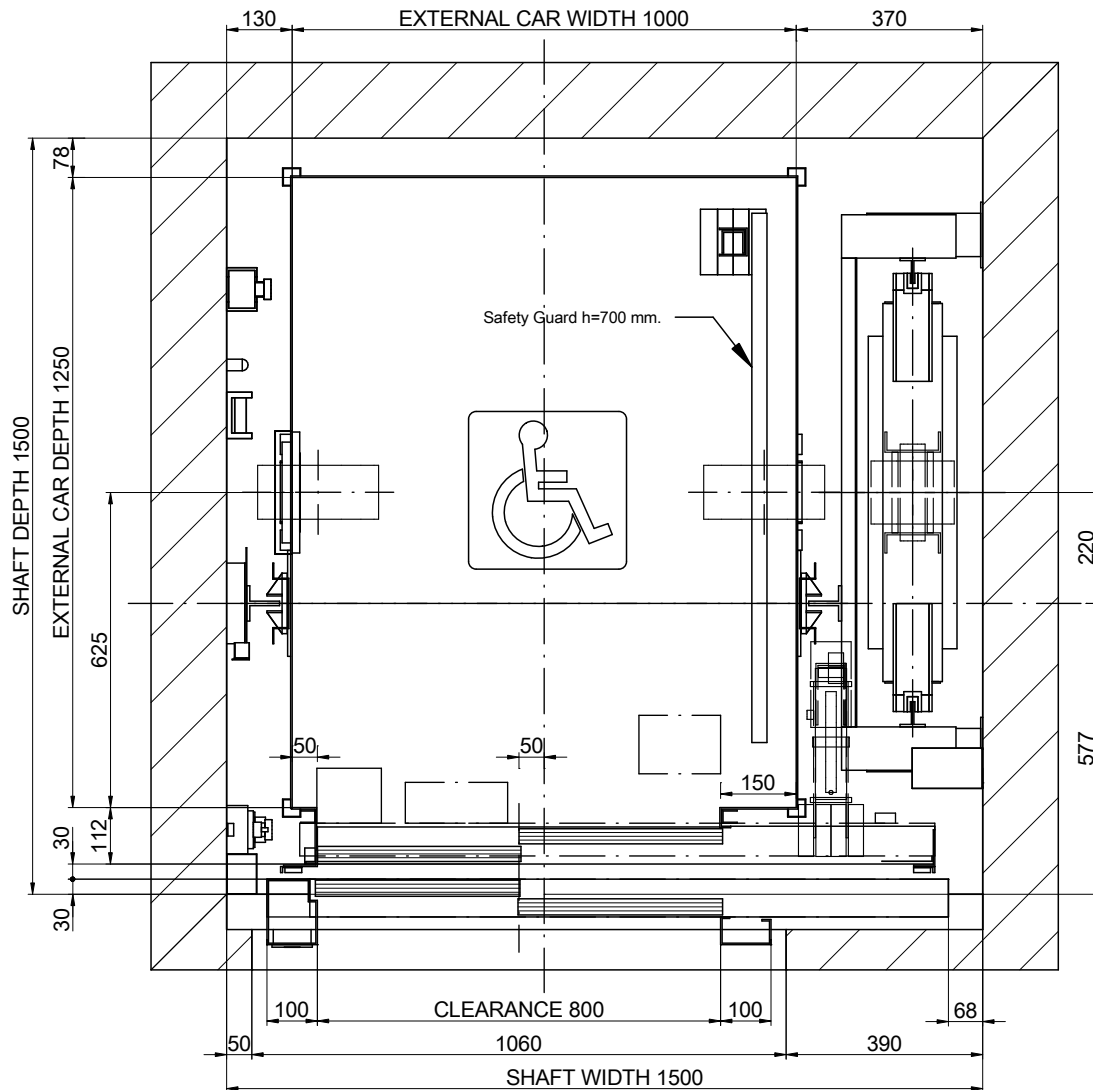

01-PLAN VIEW



SCALE[*]: 1:15

DRAWING	DATE	REV.	SHEET	[*] Unbounded dimensions in drawings are indicative and not binding. REFERENCE: MPGO!EVOLUTION480ST2_EN	
MP	2017	00	1/8		
MODEL LIFT:				CLIENT:	
MP GO! EVOLUTION					
CAPACITY: [N° PERSONS]		6		WORK SITUATION:	
NOMINAL LOAD: [kg]		480			
SPEED: [m/s]		1			
FREQUENCY: [Hz]		50			
TENSION: [V]		380V [Three-phase]			
				MP LIFTS	

01B-PLAN VIEW

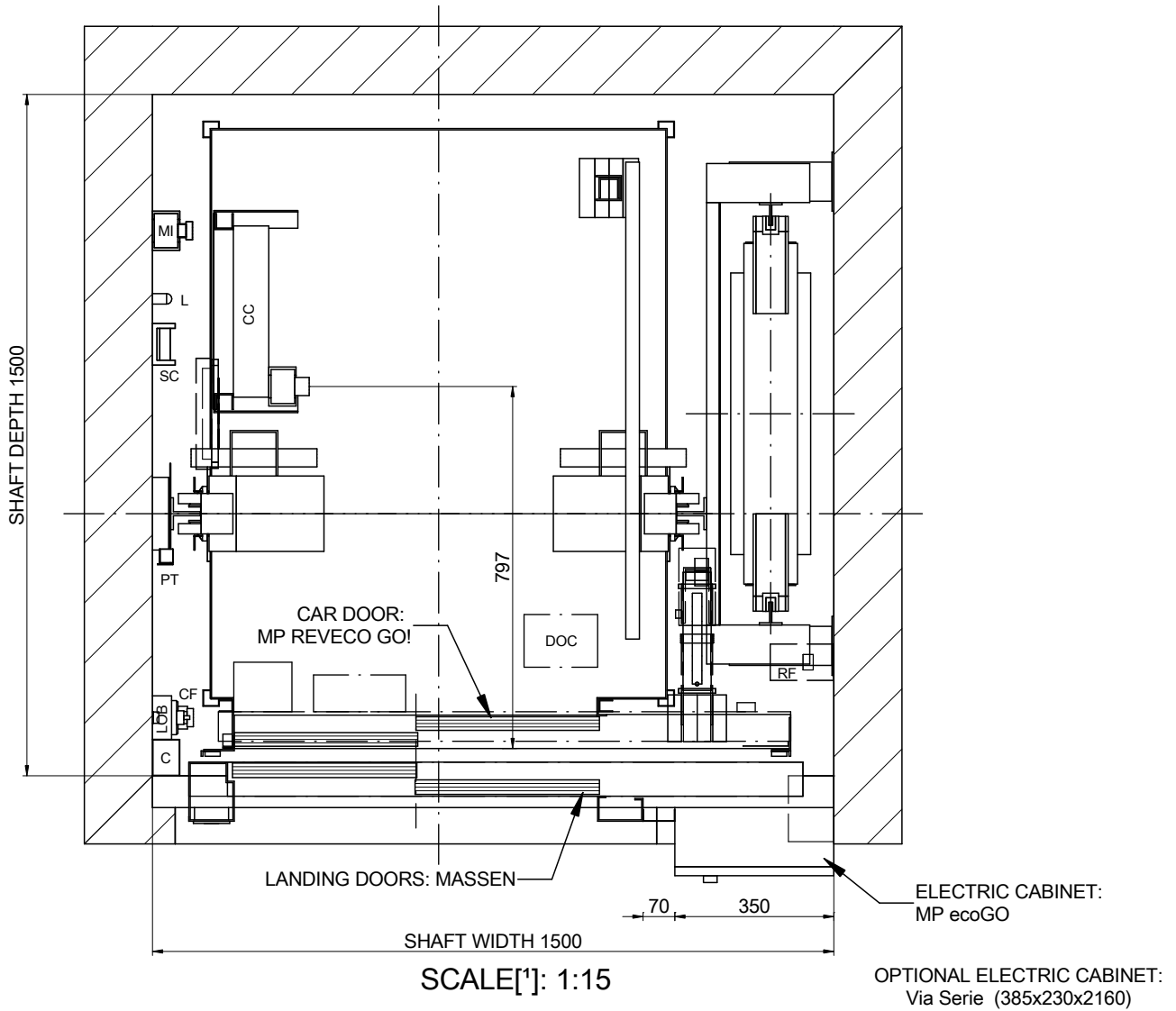

NOMENCLATURE

C: Wiring channel
 CC: Car ceiling connection box
 CF: Pit box
 CL: Shaft light switch
 DOC: Operator control box
 L: Lamp
 LOB: Pushbutton control board
 MI: Inspection control station
 PT: Fixed cam
 RF: Brake resistor
 ST: Stopping device
 SC: Travelling cable support

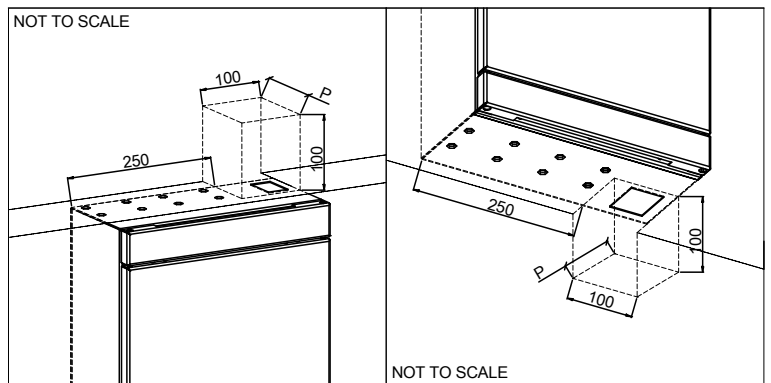

DRAWING	DATE	REV.	SHEET	[*] Unbounded dimensions in drawings are indicative and not binding. REFERENCE: MPGO!EVOLUTION480ST2_EN	
MP	2017	00	2/8		
MODEL LIFT:				CLIENT:	WORK SITUATION:
MP GO! EVOLUTION					
CAPACITY: [N° PERSONS]			6		
NOMINAL LOAD: [kg]			480		
SPEED: [m/s]			1		
FREQUENCY: [Hz]			50		
TENSION: [V]			380V [Three-phase]	MP LIFTS	

02-SIDE VERTICAL SECTION

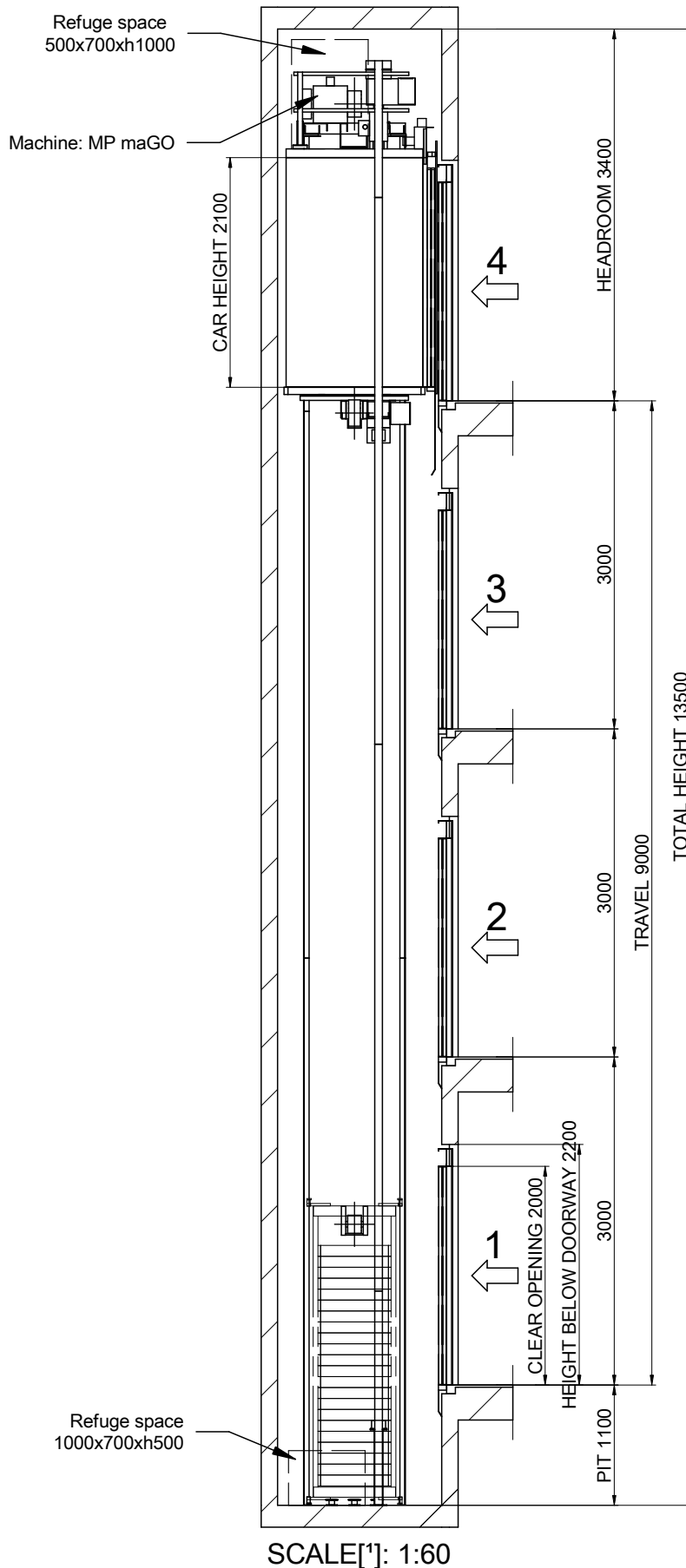

DRAWING		DATE		REV.	SHEET	MP	MP LIFTS	
		2017	00	3/8				
MODEL LIFT:		MP GO! EVOLUTION					REFERENCE:	MPGO!EVOLUTION480ST2_EN
CAPACITY: [N° PERSONS]		6					CLIENT:	
NOMINAL LOAD: [kg]		480					WORK SITUATION:	
SPEED: [m/s]		1						
FREQUENCY: [Hz]		50						
TENSION: [V]		380V [Three-phase]						

Flat and levelled floor, protected against water leaking. [EN81-20:2014 5.2.1.9]
 Foresee pit access device [EN81-20:2014 5.2.2.4]
 Stop device [EN81-20:2014 5.2.1.5.1. a]
 Inspection control station. [EN81-20:2014 5.2.1.5.1. b]
 Power supply [EN81-20:2014 5.2.1.5.1. c]
 Light switch commuted with the cabinet. [EN81-20:2014 5.2.1.5.1. d]



03B-FIXING DETAILS IN HEADROOM

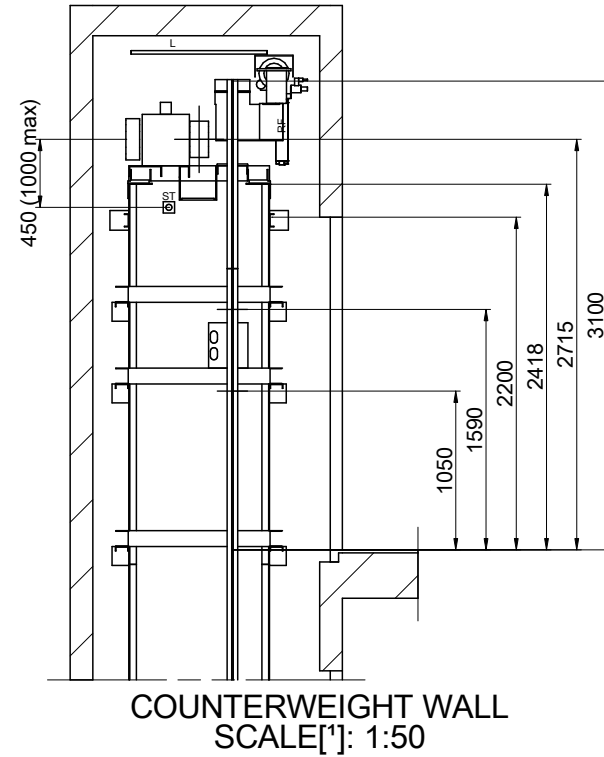
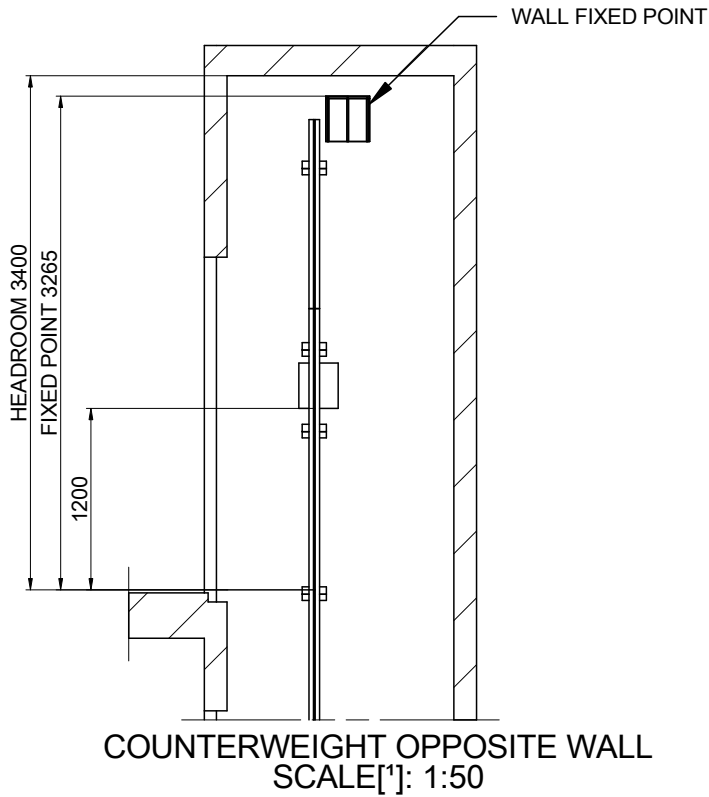

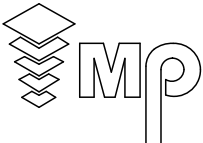
DRAWING	DATE	REV.	SHEET	[*] Unbounded dimensions in drawings are indicative and not binding.	
MP	2017	00	4/8		
MODEL LIFT:				REFERENCE: MPGO!EVOLUTION480ST2_EN	
MP GO! EVOLUTION				CLIENT:	
CAPACITY: [N° PERSONS]			6	WORK SITUATION:	
NOMINAL LOAD: [kg]			480		
SPEED: [m/s]			1		
FREQUENCY: [Hz]			50		
TENSION: [V]		380V [Three-phase]		MP LIFTS	

04-BEAM AND LIFTING HOOKS

POSITION OF REMOVABLE LIFTING HOOKS ABLE TO SUPPORT
1000 kg EACH ONE SUPPLIED BY CONSTRUCTOR
(RECOMMENDED POSITION LOADHOOKS)

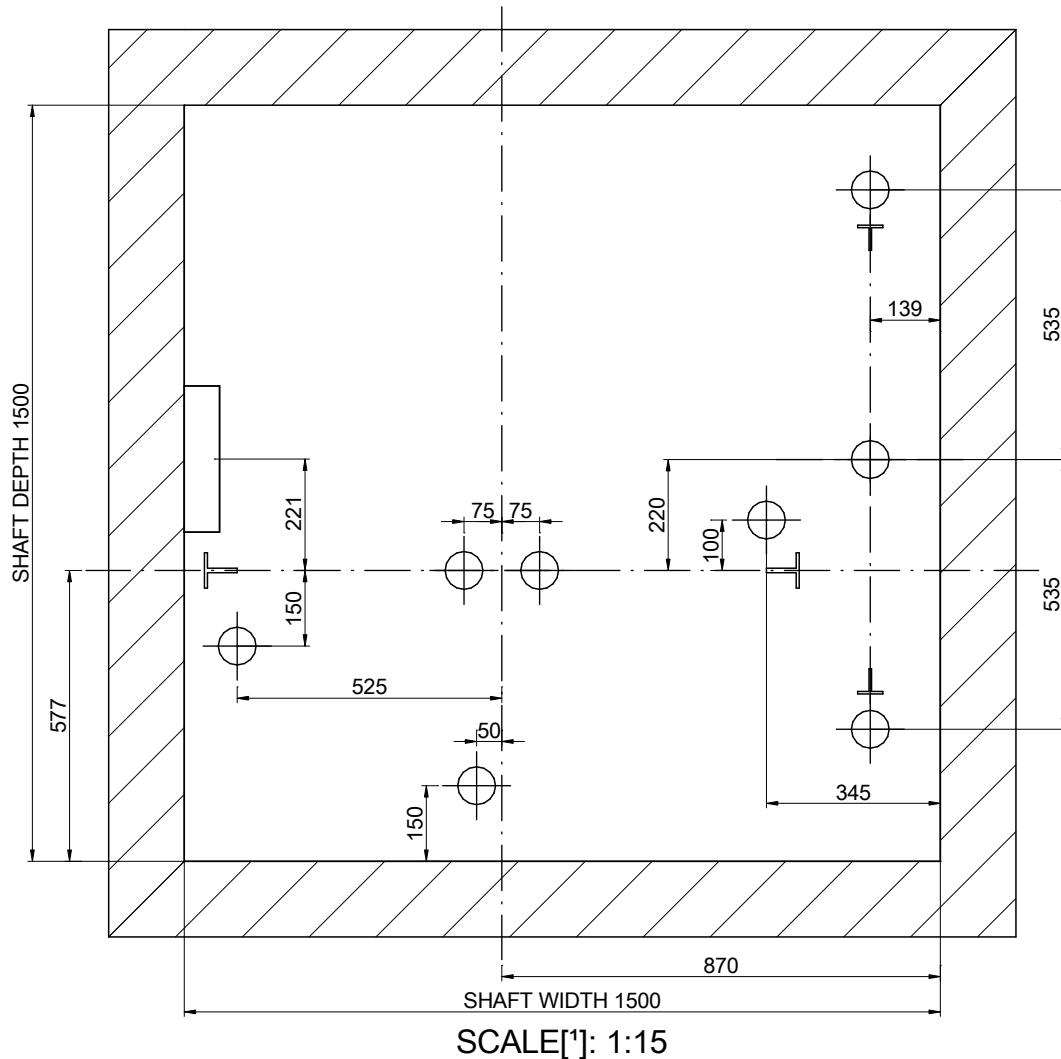

DRAWING	DATE	REV.	SHEET	[*] Unbounded dimensions in drawings are indicative and not binding.	
MP	2017	00	5/8	REFERENCE: MPGO!EVOLUTION480ST2_EN	
MODEL LIFT:				CLIENT:	<p>MP LIFTS</p>
MP GO! EVOLUTION				WORK SITUATION:	
CAPACITY: [N° PERSONS]			6		
NOMINAL LOAD: [kg]			480		
SPEED: [m/s]			1		
FREQUENCY: [Hz]			50		
TENSION: [V]			380V [Three-phase]		

05-PIT LAYOUT

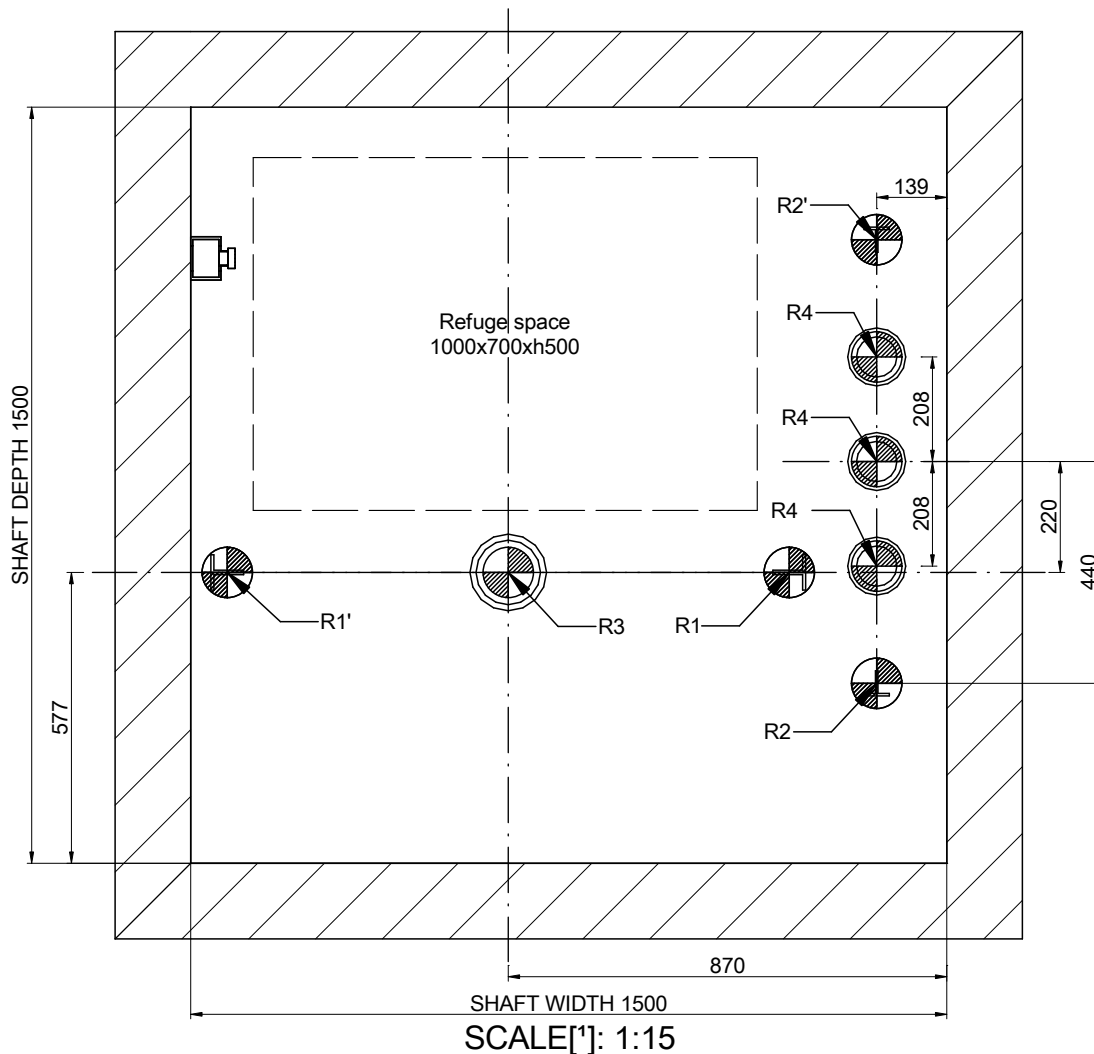



REACTIONS [N] [max.]			
R1	28000	R2	20500
R1'	25000	R2'	21000
R3	57000	R4	16000
N	1800	T	850

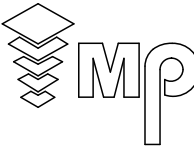

DRAWING	DATE	REV.	SHEET	[*] Unbounded dimensions in drawings are indicative and not binding.	
MP	2017	00	6/8	REFERENCE: MPGO!EVOLUTION480ST2_EN	
MODEL LIFT:				CLIENT: WORK SITUATION:	<p>MP LIFTS</p>
MP GO! EVOLUTION					
CAPACITY: [N° PERSONS]		6			
NOMINAL LOAD: [kg]		480			
SPEED: [m/s]		1			
FREQUENCY: [Hz]		50			
TENSION: [V]		380V [Three-phase]			

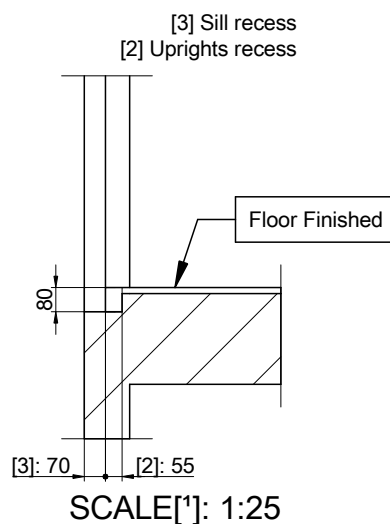
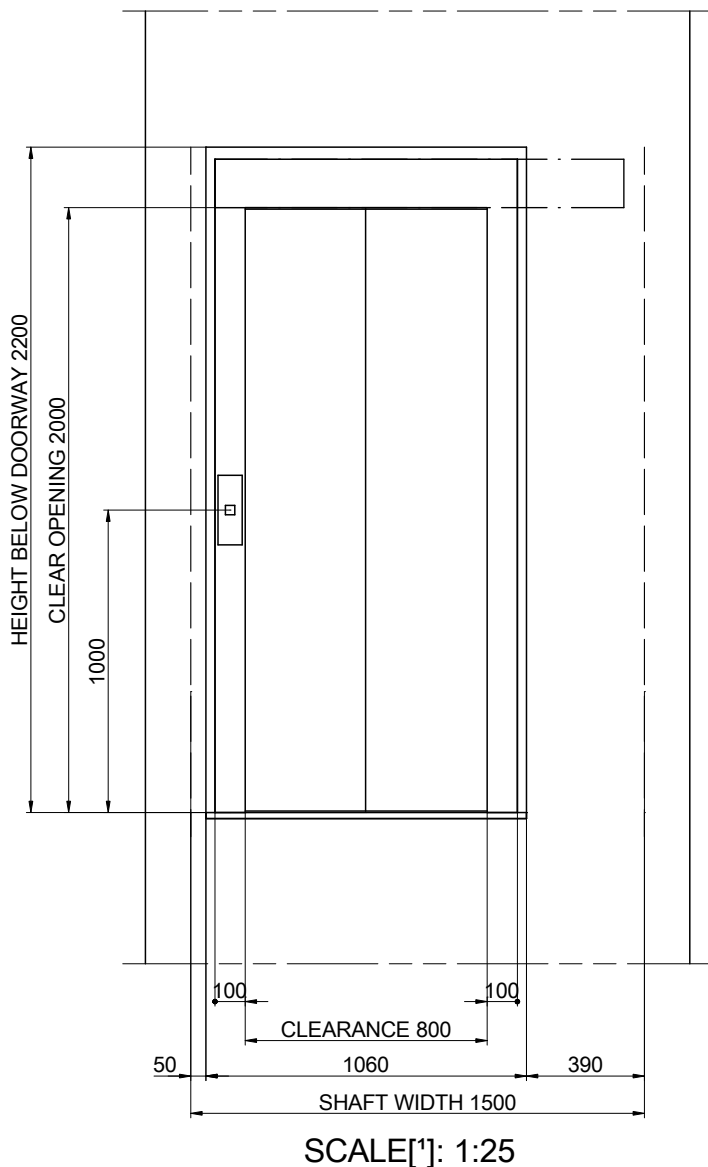
06-DOOR HOLE DETAIL



DRAWING	DATE	REV.	SHEET	[*] Unbounded dimensions in drawings are indicative and not binding.	
MP	2017	00	7/8	REFERENCE: MPGO!EVOLUTION480ST2_EN	
MODEL LIFT:				CLIENT: WORK SITUATION:	
MP GO! EVOLUTION					
CAPACITY: [N° PERSONS]			6		
NOMINAL LOAD: [kg]			480		
SPEED: [m/s]			1		
FREQUENCY: [Hz]			50		
TENSION: [V]			380V [Three-phase]	MP LIFTS	

07-HEADROOM

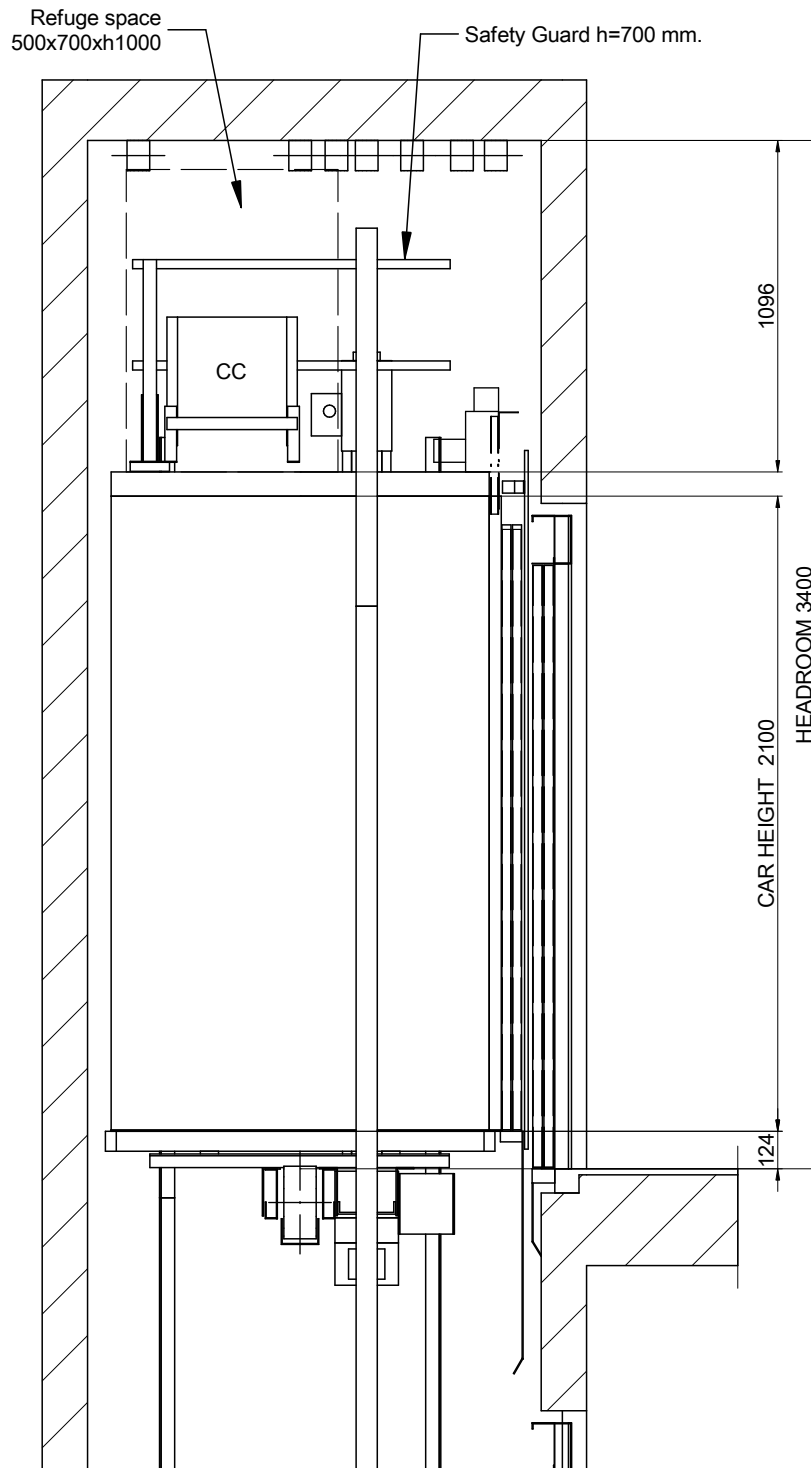

SCALE[*]: 1:25

DRAWING	DATE	REV.	SHEET	[*] Unbounded dimensions in drawings are indicative and not binding.	
MP	2017	00	8/8	REFERENCE: MPGO!EVOLUTION480ST2_EN	
MODEL LIFT:				CLIENT:	<h2>MP LIFTS</h2>
MP GO! EVOLUTION				WORK SITUATION:	
CAPACITY: [N° PERSONS]			6		
NOMINAL LOAD: [kg]			480		
SPEED: [m/s]			1		
FREQUENCY: [Hz]			50		
TENSION: [V]		380V [Three-phase]			